

VACUUM PUMP DS05



공급 압력 / Feed pressure : 0.4 ~ 0.6 MPa
 에어 소모량 / Air consumption : 11.5 Nℓ/m
 최대 진공 / Max vacuum : - 85 kPa
 소음도 / Noise level : 50dBA
 재질 / Material : Brass, AL
 사용온도 / Working temperature : - 20 ~ 80℃
 중량 / Weight : 14.5 g

Order no.

DS05 ① — ② — ③ — ④

① 스프링 플런저 SPRING PLUNGER

X : 없음 (NONE)
 07 : SPM507 - V (7 Stroke)
 10 : SPM510 - V (10 Stroke)
 15 : SPM515 - V (15 Stroke)
 20 : SPM520 - V (20 Stroke)
 40 : SPM540 - V (40 Stroke)
 50 : SPM550 - V (50 Stroke)

② 흡입 컵 유형 SUCTION CUP TYPE

X : 없음 (NONE)
 MB : MB Type
 MU : MU Type
 MF : MF Type
 MD : MD Type

③ 흡입 컵 지름(∅) SUCTION PAD DIA

X : 없음 (NONE)	10 : ∅10 (MB, MU)
2 : ∅2 (MU)	15 : ∅15 (MB, MF, MU)
4 : ∅4 (MU)	20 : ∅20 (MB, MD, MF, MU)
5 : ∅5 (MB)	25 : ∅25 (MF, MU)
6 : ∅6 (MB, MU)	26 : ∅26 (MD, MF)
8 : ∅8 (MB, MU)	30 : ∅30 (MU)

MB Type : 5, 6, 8, 10, 15, 20
 MU Type : 2, 4, 6, 8, 10, 15, 20, 25, 30
 MF Type : 15, 20, 25, 26
 MD Type : 20, 26

④ 흡입 컵 재질 SUCTION CUP MATERIAL

X : 없음 (NONE)	U : URETHEN
N : NBR	HS : HIGH TEMP SILICON
S : SILICON	WS : WHITE SILICON
CS : C. SILICON	V : VITON

각 진공도에 따른 흡입유량
Vacuum flow (Nℓ/min) at different vacuum levels (-kPa)

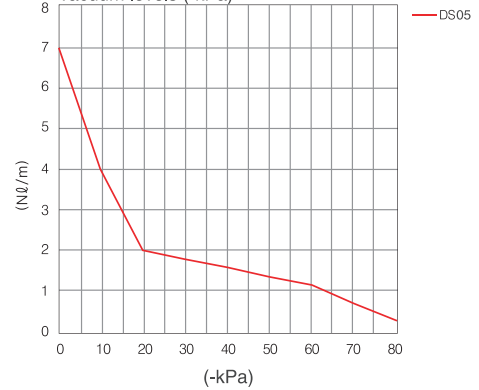

각 진공도까지 도달시간
Evacuation (s/ℓ) to reach different vacuum levels (-kPa)

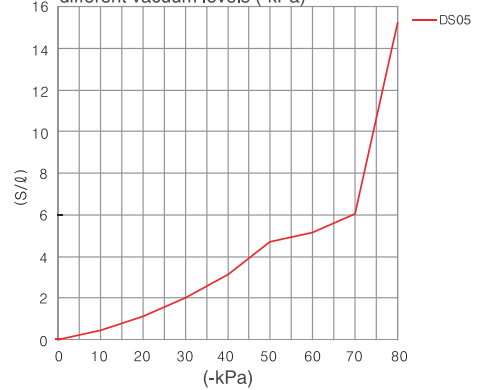

※품질 향상을 위해 예고없이 사양이 변경될 수 있음.
Specifications subject to change without notice.

DESIGN DATA

펌프의 특징 / Pump Characteristics

MODEL	최대 진공 Max. Vacuum -kPa(-mmHg)	최대 진공 유량 Max. Vacuum flow (Nℓ/min)	에어 소모량 Air consumption (Nℓ/min)	소음도 noise level (dBA)	중량 weight(g)	최소 호스 내경 ∅ (2m 이내) Min hose inner ∅ (within 2m)		
						공급 air supply	진공 vacuum	배기 exhaust
DS05	-85 (-637.5)	7	11.5	50	14.5	>2	>4	>4

진공흡입유량 (Nℓ/min) / Induce air in liters per minute (Nℓ/min)

MODEL	0(-mmHg)	75	150	225	300	375	450	525	600
	0(-kPa)	10	20	30	40	50	60	70	80
DS05	7	4	2	1.78	1.57	1.35	1.14	0.69	0.28

진공도달시간 (sec/ℓ) / Time in seconds to evacuate to vacuum level (sec /ℓ)

MODEL	75(-mmHg)	150	225	300	375	450	525	600
	10 (-kPa)	20	30	40	50	60	70	80
DS05	0.44	1.12	2	3.16	4.72	5.16	6.06	15.22

DIMENSION

DS05

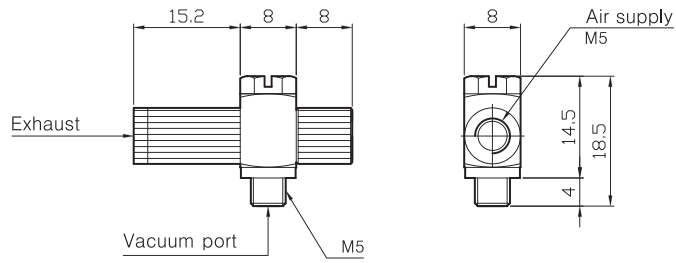

DSK05

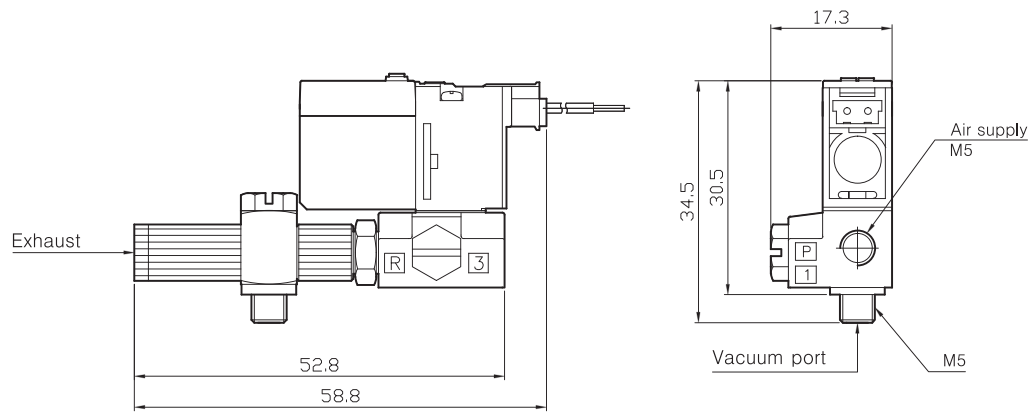

DS05 + Plunger + Suction cup

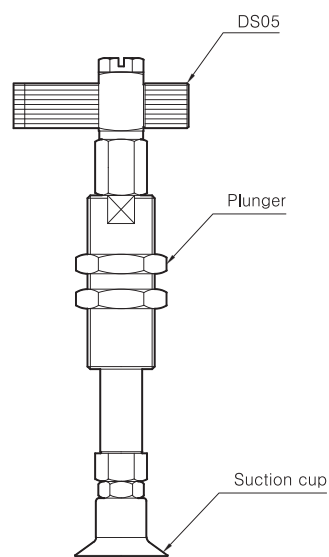

DSK05 + Plunger + Suction cup

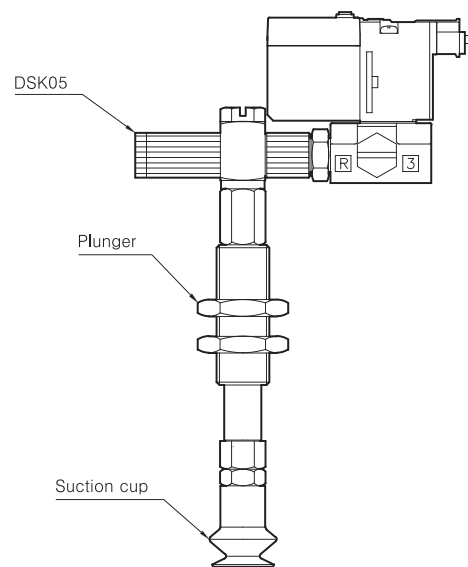

※품질 향상을 위해 예고없이 사양이 변경될 수 있음.
Specifications subject to change without notice.