

VACUUM PUMP SMR



공급 압력 / Feed pressure	: 0.4 ~ 0.6 MPa
에어 소모량 / Air consumption	: 300 ~ 1260 Nℓ/m
최대 진공 / Max vacuum	: - 92 kPa
소음도 / Noise level	: 60 ~ 80 dBA
재질 / Material	: PPS, AL
사용온도 / Working temperature	: - 20 ~ 80 °C
중량 / Weight	: 678 ~ 1730g

Order no.

SMR ①

① 용량 / CAPACITY
전기모터펌프 동일한 용량
Capacity equivalent to
electricity motor pump size

455	: 950 Nℓ/m (1.0 KW)
655	: 1300 Nℓ/m (1.25 KW)
665	: 1380 Nℓ/m (1.3 KW)
865	: 1580 Nℓ/m (1.5 KW)
1085	: 2725 Nℓ/m (1.6 KW)
1285	: 3300 Nℓ/m (2.0 KW)

※ Seal : NBR (표준 / Standard)

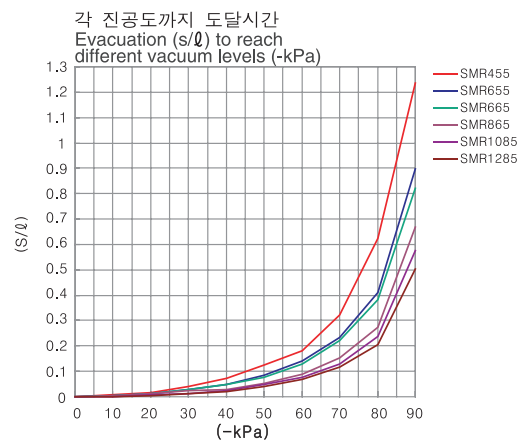
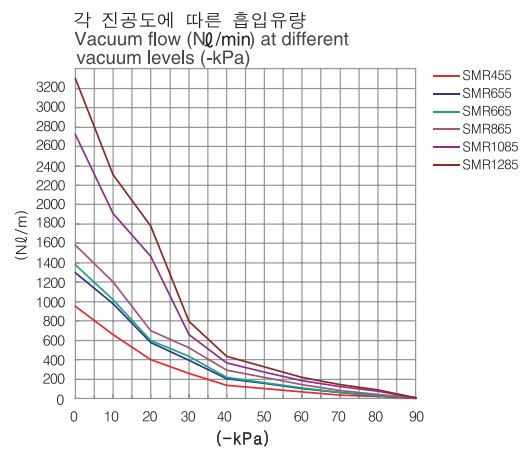

※품질 향상을 위해 예고없이 사양이 변경될 수 있음.
Specifications subject to change without notice.

DESIGN DATA

펌프의 특징 / Pump Characteristics

MODEL	최대 진공 Max. Vacuum -kPa(-mmHg)	최대 진공 유량 Max. Vacuum flow(Nℓ/min)	에어 소모량 Air consumption (Nℓ/min)	소음도 noise level (dBA)	중량 weight (g)	최소 호스 내경∅(2m 이내) Min hose inner∅(within 2m)		
						공급 air supply	진공 vacuum	배기 exhaust
SMR455	-92 (-690)	950	300 ~ 420	60 ~ 65	678	>8	>19	>22
SMR655		1300	450 ~ 630	60 ~ 70	679.7	>8	>19	>22
SMR665		1380	450 ~ 630	60 ~ 70	1046	>8	>19	>22
SMR865		1580	600 ~ 840	60 ~ 75	1050	>10	>25	>32
SMR1085		2725	800 ~ 1020	60 ~ 75	1724	>10	>32	>40
SMR1285		3300	900 ~ 1260	60 ~ 80	1730	>10	>32	>40

진공흡입유량 (Nℓ/min) / Induce air in liters per minute (Nℓ/min)

MODEL	-mmHg -kPa	0 (-mmHg)	75	150	225	300	375	450	525	600	675
		0 (-kPa)	10	20	30	40	50	60	70	80	90
SMR455	950	950	656	400	260	133	100	66	37	19	3
SMR655	1300	1300	975	575	391	203	153	103	58	29	4.6
SMR665	1380	1380	1020	597	436	218	162	108	60	30	4.8
SMR865	1580	1580	1200	701	521	290	216	144	80	40	6.4
SMR1085	2725	2725	1908	1469	661	364	273	183	119	73	8.76
SMR1285	3300	3300	2310	1781	793	435	324	216	140	85	9.6

진공도달시간 (sec/ℓ) / Time in seconds to evacuate to vacuum level (sec /ℓ)

MODEL	-mmHg -kPa	75 (-mmHg)	150	225	300	375	450	525	600	675
		10 (-kPa)	20	30	40	50	60	70	80	90
SMR455	950	0.007	0.016	0.042	0.072	0.123	0.182	0.322	0.625	1.235
SMR655	1300	0.005	0.014	0.030	0.050	0.085	0.141	0.232	0.410	0.897
SMR665	1380	0.005	0.014	0.029	0.047	0.078	0.129	0.223	0.394	0.823
SMR865	1580	0.004	0.012	0.026	0.027	0.054	0.090	0.153	0.274	0.67
SMR1085	2725	0.002	0.007	0.014	0.026	0.048	0.078	0.127	0.237	0.574
SMR1285	3300	0.002	0.006	0.012	0.022	0.041	0.068	0.115	0.206	0.503

※품질 향상을 위해 예고없이 사양이 변경될 수 있음.
Specifications subject to change without notice.

DIMENSION

SMR455/655

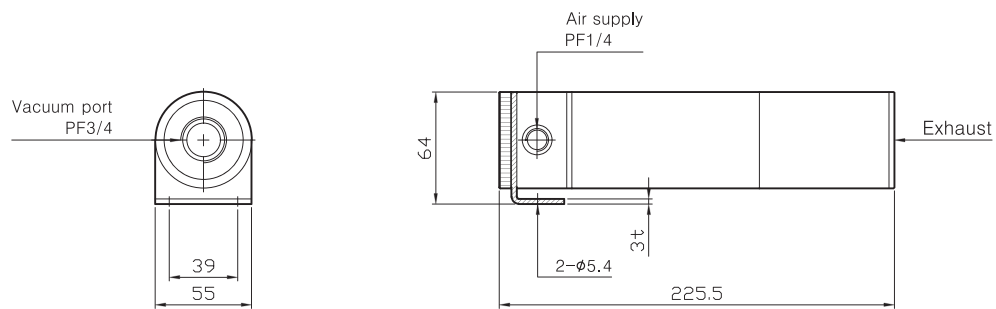

SMR665/865

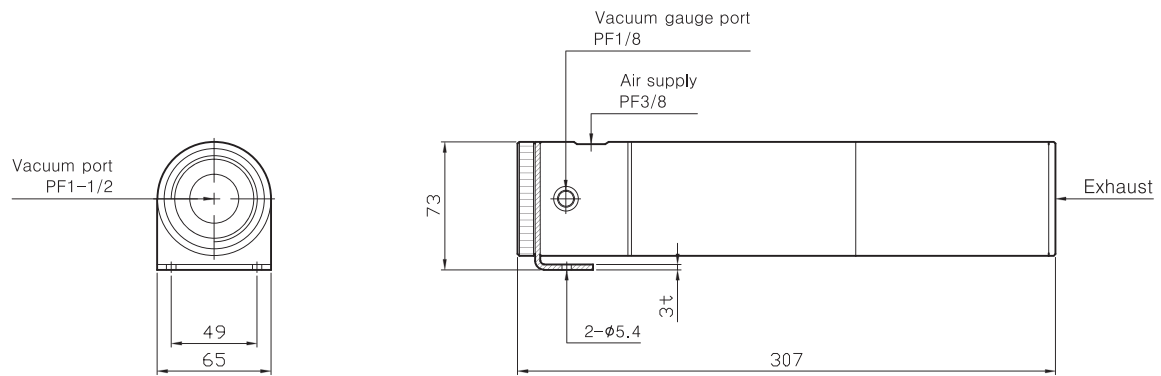

SMR1085/1285

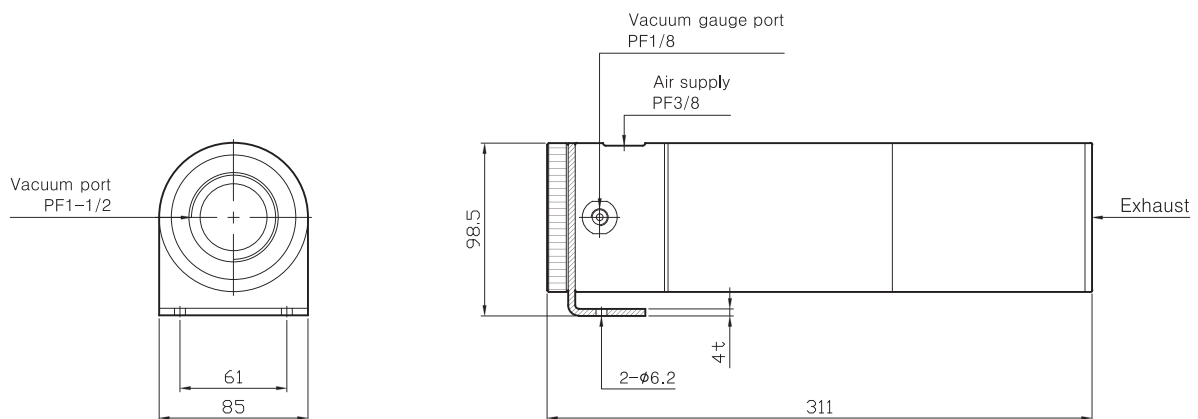

※품질 향상을 위해 예고없이 사양이 변경될 수 있음.
Specifications subject to change without notice.