

VACUUM PUMP VSM-D/VSX-D



공급 압력 / Feed pressure : 0.4 ~ 0.6 MPa
 에어 소모량 / Air consumption : 60 ~ 288 Nℓ/m
 최대 진공 / Max vacuum : - 85 ~ - 92 kPa
 소음도 / Noise level : 57 ~ 65 dBA
 재질 / Material : PPS, AL
 사용온도 / Working temperature : - 20 ~ 80 °C
 중량 / Weight : 179 ~ 338 g

Order no.

VS ① D - ② - ③

① 모델 / MODEL

M04	X04
M06	X06
M08	X08
M10	X10
M12	X12

② 씬링 / SEALING

N	: NBR (표준 씬 / Standard seal)
V	: VITON
E	: EPDM
NR	: NON RETURN VALVE & NBR SEAL
NV	: NON RETURN VALVE & VITON SEAL
NE	: NON RETURN VALVE & EPDM SEAL

③ 진공센서 & 진공스위치 (옵션) VACUUM SENSOR & VACUUM SWITCH (OPTION)

X	: 없음 (NONE)
S	: NPN (2점출력 / out put 2 point)
PS	: PNP (2점출력 / out put 2 point)
MS	: 기계식 진공스위치 부착 / Mechanical Vacuum Switch mount

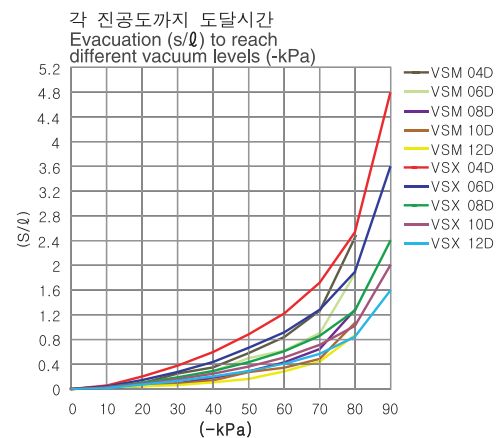
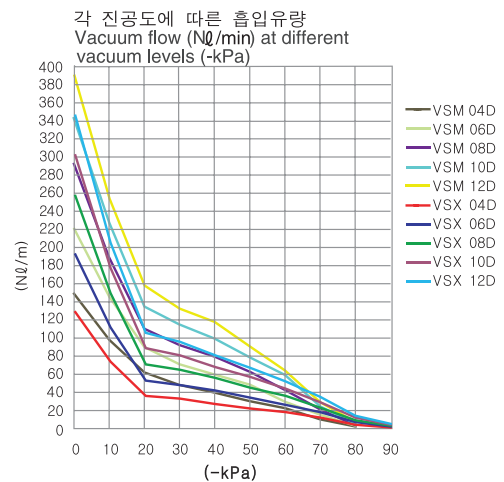

※품질 향상을 위해 예고없이 사양이 변경될 수 있음.
Specifications subject to change without notice.

DESIGN DATA

펌프의 특징 / Pump Characteristics

MODEL	최대 진공 Max.Vacuum -kPa(-mmHg)	최대 진공 유량 Max.Vacuum flow(Nℓ/min)	에어 소모량 Air consumption (Nℓ/min)	소음도 noise level (dBA)	중량 weight (g)	최소 호스 내경 \varnothing (2m 이내) Min hose inner \varnothing (within 2m)		
						공급 air supply	진공 vacuum	배기 exhaust
VSM 04D	-85 (-637.5)	149	60 ~ 84	57 ~ 58	179	>4	>10	>12
VSM 06D		220	90 ~ 126	57 ~ 58	190	>6	>10	>12
VSM 08D		292	120 ~ 168	57 ~ 60	321	>6	>12	>15
VSM 10D		341	150 ~ 216	58 ~ 63	329	>8	>12	>18
VSM 12D		390	180 ~ 252	60 ~ 65	338	>8	>15	>18
VSX 04D	-92 (-690)	124	86 ~ 96	57 ~ 60	179	>4	>10	>12
VSX 06D		185	129 ~ 144	57 ~ 63	190	>6	>10	>12
VSX 08D		247	172 ~ 192	60 ~ 63	321	>6	>12	>15
VSX 10D		290	216 ~ 240	60 ~ 65	329	>8	>12	>18
VSX 12D		332	259 ~ 288	60 ~ 65	338	>8	>15	>18

진공흡입유량 (Nℓ/min) / Induce air in liters per minute (Nℓ/min)

MODEL	-mmHg -kPa	0 (-mmHg)	75	150	225	300	375	450	525	600	675
		0 (-kPa)	10	20	30	40	50	60	70	80	90
VSM 04D	149	99	62	54	40	32	22	10.5	2.7		
VSM 06D	220	147	92	73	60	47	32	16	4.1		
VSM 08D	292	200	110	93	80	63	43	21	5.4		
VSM 10D	341	228	135	115	100	79	60	24	6.6		
VSM 12D	390	256	159	137	119	94	64	32	8.5		
VSX 04D	124	72	35	32	27	22	18	12	4.8	1.8	
VSX 06D	185	108	52	47	41	33	26	18	7.2	2.8	
VSX 08D	247	144	69	63	54	44	35	23	9.6	3.6	
VSX 10D	290	171	86	78	66	55	43	29	12	4.5	
VSX 12D	332	198	102	93	78	65	51	34	14.4	5.4	

진공도달시간 (sec/ℓ) / Time in seconds to evacuate to vacuum level (sec/ℓ)

MODEL	-mmHg -kPa	75 (-mmHg)	150	225	300	375	450	525	600	675
		10 (-kPa)	20	30	40	50	60	70	80	90
VSM 04D	0.054	0.139	0.25	0.394	0.589	0.86	1.317	2.579		
VSM 06D	0.041	0.104	0.186	0.295	0.441	0.647	0.898	1.935		
VSM 08D	0.027	0.069	0.125	0.197	0.294	0.431	0.658	1.289		
VSM 10D	0.023	0.058	0.104	0.164	0.245	0.359	0.549	1.074		
VSM 12D	0.018	0.046	0.083	0.131	0.196	0.286	0.439	0.859		
VSX 04D	0.064	0.199	0.379	0.6	0.89	1.227	1.722	2.54	4.797	
VSX 06D	0.048	0.149	0.284	0.44	0.673	0.917	1.287	1.906	3.595	
VSX 08D	0.032	0.099	0.189	0.29	0.445	0.613	0.858	1.273	2.398	
VSX 10D	0.027	0.083	0.158	0.25	0.371	0.511	0.714	1.016	1.999	
VSX 12D	0.021	0.067	0.126	0.2	0.297	0.409	0.569	0.848	1.599	

※품질 향상을 위해 예고없이 사양이 변경될 수 있음.
Specifications subject to change without notice.

DIMENSION

VSM/VSX 'D' type (without switch)
VSM/VSX(02D, 04D, 06D)

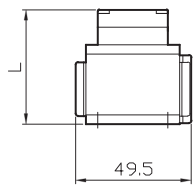
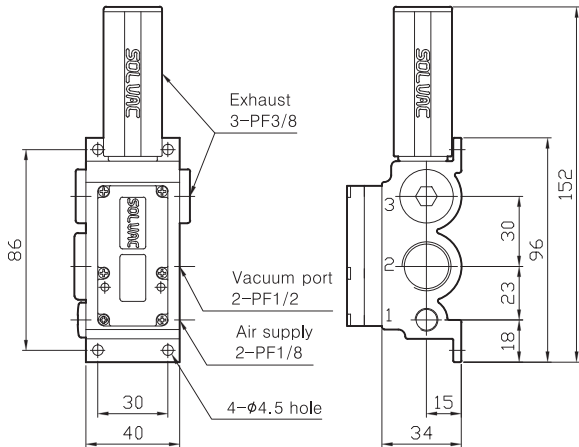

MODEL	L (mm)
(VSM/VSX)02D - (N) - X	41.5
(VSM/VSX)04D - (N) - X	49
(VSM/VSX)06D - (N) - X	56.5

VSM/VSX 'D' type (with switch)
VSM/VSX(02D, 04D, 06D)

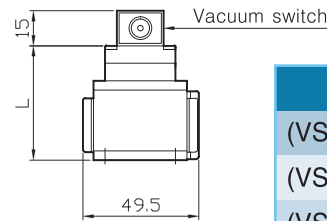
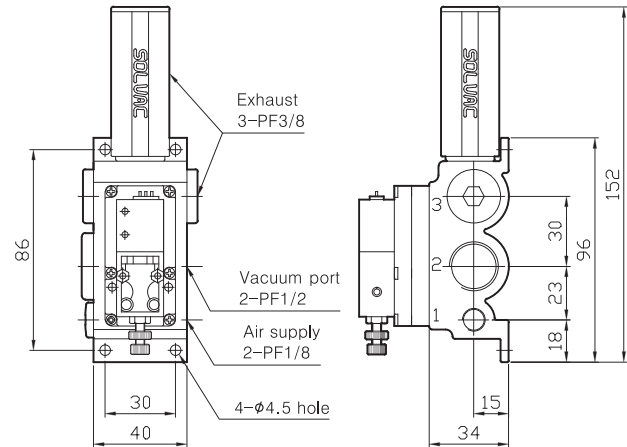

MODEL	L (mm)
(VSM/VSX)02D - (N) - MS	41.5
(VSM/VSX)04D - (N) - MS	49
(VSM/VSX)06D - (N) - MS	56.5

VSM/VSX 'D' type (without switch)
VSM/VSX(08D, 10D, 12D)

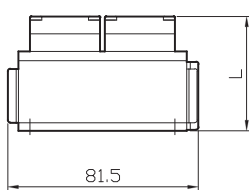
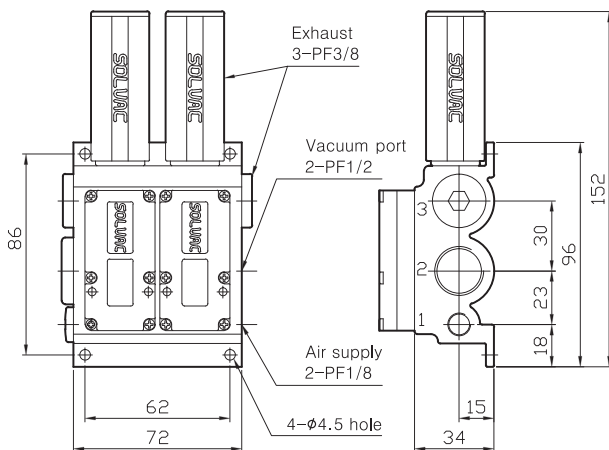

MODEL	L (mm)
(VSM/VSX)08D - (N) - X	41.5
(VSM/VSX)10D - (N) - X	49
(VSM/VSX)12D - (N) - X	56.5

VSM/VSX 'D' type (with switch)
VSM/VSX(08D, 10D, 12D)

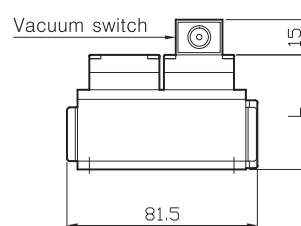
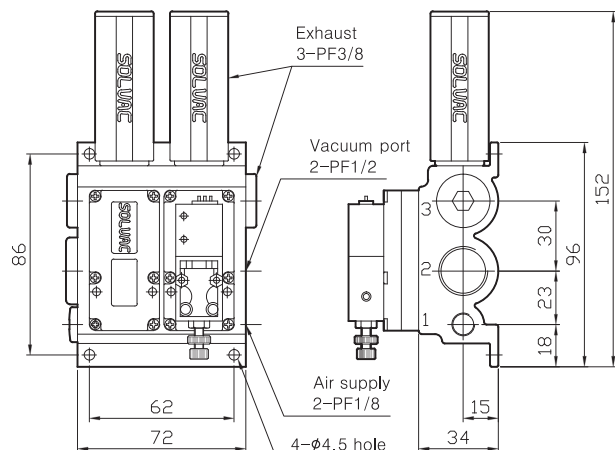

MODEL	L (mm)
(VSM/VSX)08D - (N) - MS	41.5
(VSM/VSX)10D - (N) - MS	49
(VSM/VSX)12D - (N) - MS	56.5

※품질 향상을 위해 예고없이 사양이 변경될 수 있음.
Specifications subject to change without notice.

DIMENSION

VSM/VSX 'D' type (with sensor)
 VSM/VSX(02D-N-S, 04D-N-S, 06D-N-S)

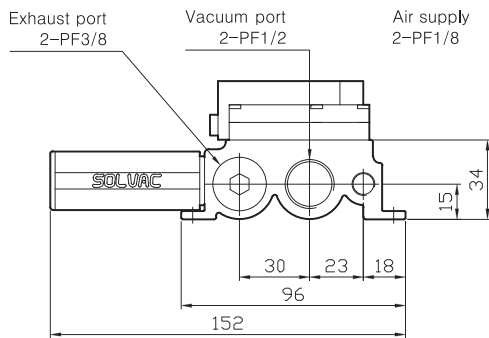
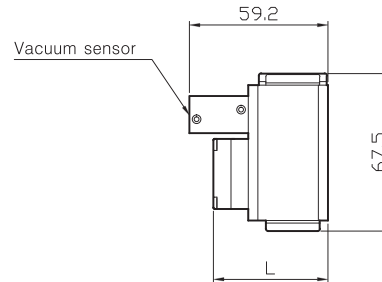
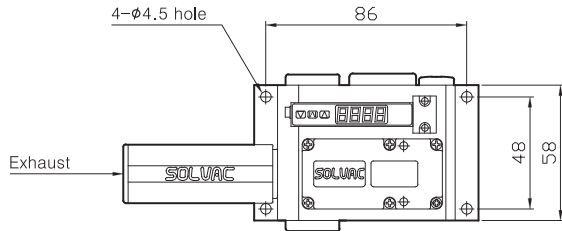

MODEL	L (mm)
(VSM/VSX)02D - (N) - S	41.5
(VSM/VSX)04D - (N) - S	49
(VSM/VSX)06D - (N) - S	56.5

VSM/VSX 'D' type (with sensor)
 VSM/VSX(08D-N-S, 10D-N-S, 12D-N-S)

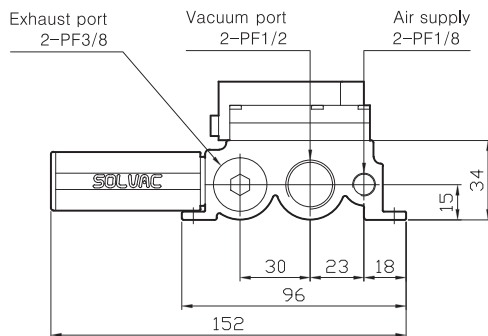
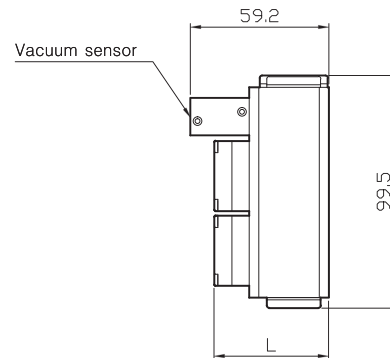
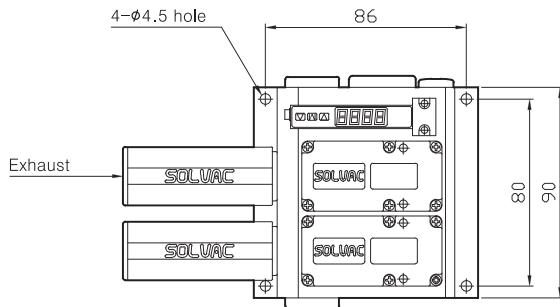

MODEL	L (mm)
(VSM/VSX)08D - (N) - S	41.5
(VSM/VSX)10D - (N) - S	49
(VSM/VSX)12D - (N) - S	56.5

※품질 향상을 위해 예고없이 사양이 변경될 수 있음.
 Specifications subject to change without notice.